

Hand Operated Motor Speed Control - Single Phase

Models 1.5 Amp, 3 Amp, 6 Amp and 10 Amp for all applications using suitable specified single phase induction motors.

WARNING

Mains voltage is present. Care must be exercised when adjusting pre-set potentiometer. It is the responsibility of the user to ensure compliance with the Health and Safety at Work Act.

GENERAL



The controllers utilise phase cutting techniques. Thus by manual adjustment of rotary control knob on the front of the controller, variable power may be applied to most permanent split capacitor, shaded pole, and Steinmetz motors.

Control is best achieved with propeller, axial or centrifugal fan loads, when absorbed power at full load corresponds to at least 90% of the motors capacity.

SPECIFICATION

Model Number	Run Current (Amps)	Maximum Start Current (Amps)	Fuse size (Amps/Length)
1.5 Amp	1.5 Amp	4.5	3.15 / 20mm
3 Amp	3 Amp	9	5 / 20mm
6 Amp	6 Amp	18	10 / 32mm
10 Amp	10 Amp	30	16 / 32mm

The 1.5, 3, 6 and 10 Amps are designed for continuous operation at 1.5 Amps, 3 Amps, 6 Amps and 10 Amps maximum loads respectively at 40° C ambient, on single phase 230V 50/60 Hz. supply.

The controllers are compliant with   requirements.

MOTOR PROTECTION

Fuses in the unit are for protection of the controller. Should this current rating exceed that of the wiring to the fans, individual fan protection should be provided. If overload protection for each fan is to be used, then this should be situated in each common line (**UZ**) only.

INSTALLATION

Install in a dry sheltered position. Leave an airspace of not less than 15 cms. around the controller to allow cooling air to flow freely. Do not install in close proximity to other heat sources. The maximum ambient temperature must not exceed 40° C.

Removing the front cover fixing screws allows access to mounting holes and terminals. If more fans need to be controlled a junction box can be used to parallel the various connections.

An external thermostat or switch can be fitted to enable fan to run at a preset speed adjusted by the controller and maximum speed set by temperature of the thermostat or operation of the switch. Connect the thermostat or switch to the **U** and **Z** of the controller as shown in the circuit diagram.

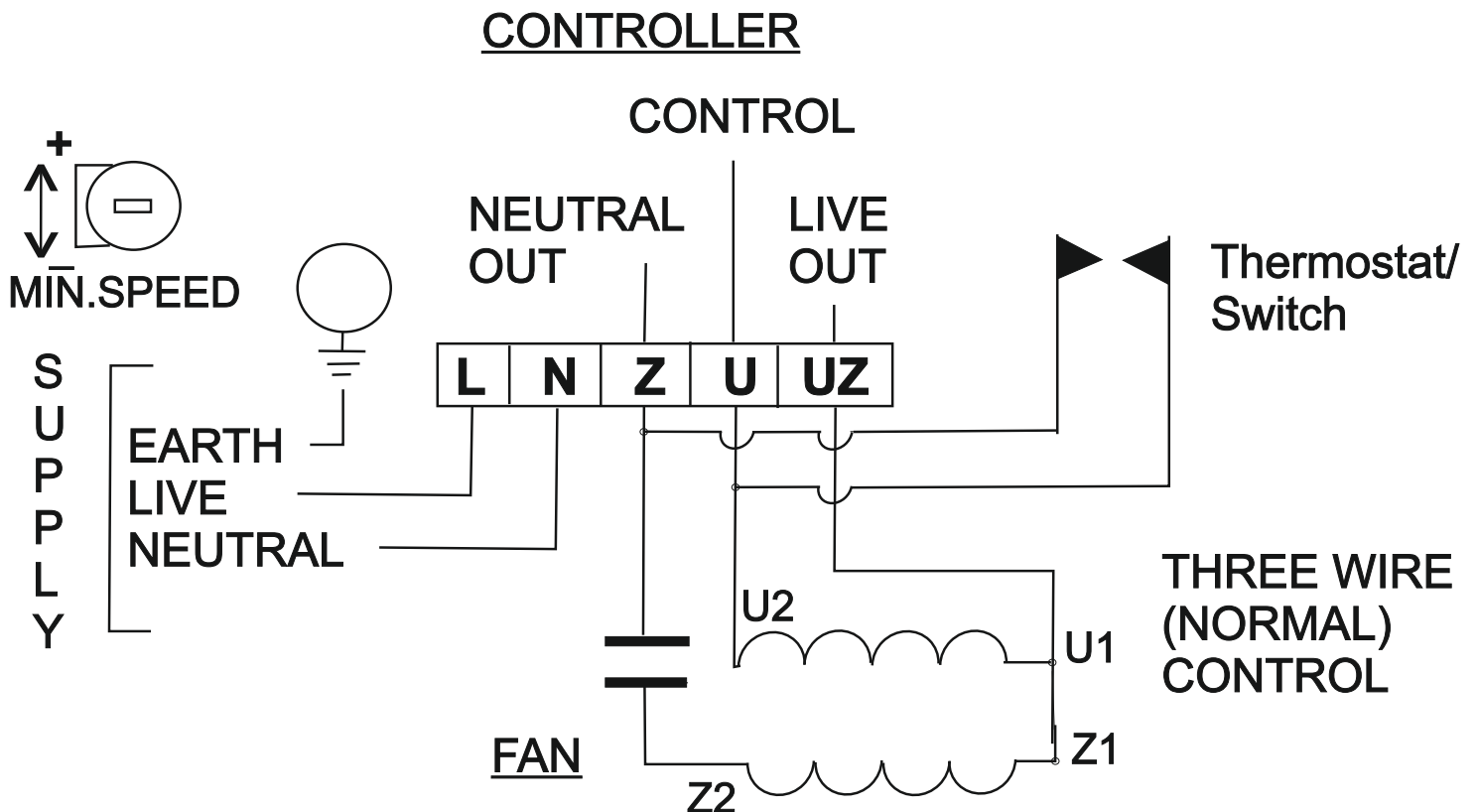

Colair Controller Terminal	Vent Axia	Woods	S &P	Elta SCP SCD	Elta SLC SMB SMC	Nuair	EBM- Ziehl	Systemair
EARTH	E	E	E	E	E	E	E	E
LIVE	L	L	L	L	L	L	L	L
NEUTRAL	N	N	N	N	N	N	N	N
Z	U	P *	AUX	4	Z2		CAP.	
U	V	U	U1	5	U1	N	U2	N
UZ	W	UZ	U2	6	U2	L	U1/Z1	L

* Remove link between P and U (if fitted)

Certain fans have inbuilt thermal protection labeled **K.K** or **(TK.TK)**. If this facility is to be utilised then the wiring from controller **UZ** only should be connected to one of the thermal protection contacts, the other contact connected to the appropriate motor contact.

CONTROLS

The controllers have separate ON/OFF switches. Rotating the control knob clockwise will increase the speed of the fan(s) from a preset minimum to full speed with infinitely variable control.

An internal mounted pre-set potentiometer sets the minimum speed of the fan(s). If this requires adjustment rotate the main control knob fully anti-clockwise and adjust the pre-set to required speed. Do not set this control too low since this will increase the risk of stall conditions.

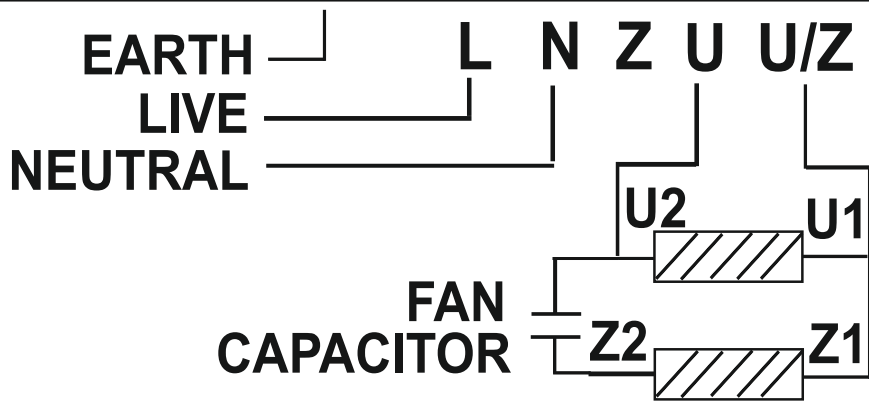
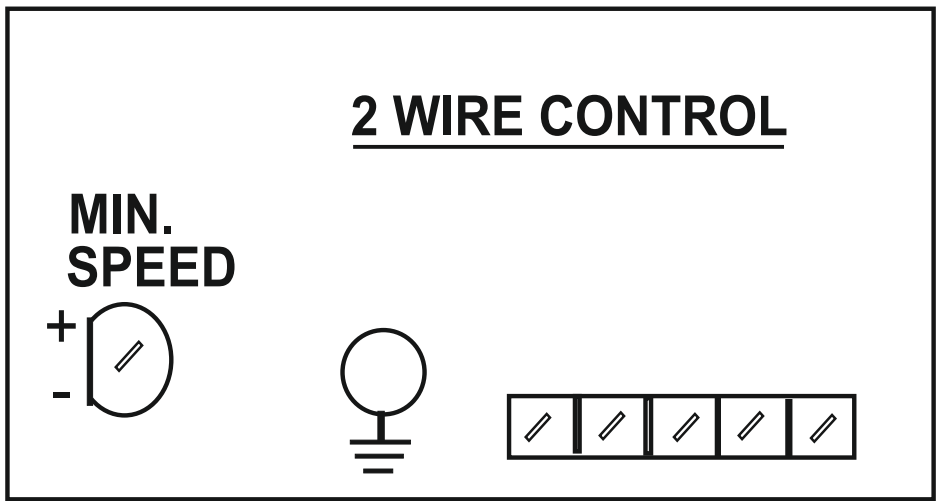

CONTROLLER WIRING DIAGRAM (for TK controllers Only)

